



SUPER SILENT



OIL FREE



SSC100PRO ***Air Compressor***

OWNER'S MANUAL

CE

SGS-ENGINEERING.COM



WARNING: Before using the compressor, please read the instructions in this manual carefully.



READ THE INSTRUCTION HANDBOOK - Before positioning, operating or adjusting the compressor, read the instruction handbook carefully.



RISK OF ELECTRIC SHOCK - Caution: disconnect power supply before attempting any maintenance.



RISK OF HIGH TEMPERATURES - Caution: the compressor contains some parts which might reach high temperatures.



RISK OF ACCIDENTAL START-UP - Caution: the compressor could start automatically after a power cut if not switched off.

SSC100PRO Parts List

Item	Product Number	Unit	Qty	Description	Item	Product Number	Unit	Qty	Description
1	909697	PCS	4	Bolt	15-22	909733	PCS	2	Seal ring
2	909698	PCS	4	Wheel	15-23	909734	PCS	2	Cylinder head
3	909699	PCS	4	Washer	15-24	909735	PCS	12	Screw
4	909700	PCS	4	Nut	15-25	909736	PCS	2	Bearing 6203
5	909701	PCS	1	Tank	15-26	909737	PCS	1	Rotor
6	909702	PCS	1	Wire locking box	15-27	909738	PCS	1	Stator
7	909703	PCS	1	Fastening gasket	15-28	909739	PCS	1	Crankcase (R)
8	909704	PCS	4	Bolt	15-29	909740	PCS	4	Spring washer
9	909705	PCS	1	Wire	15-30	909741	PCS	4	Bolt
10	909706	PCS	3	Protector	15-31	909742	PCS	1	Screw
11	909707	PCS	3	Cable clip	15-32	909743	PCS	1	Fan(R)
12	909708	PCS	3	Capacitor cover	15-33	909744	PCS	2	Circlip
13	909709	PCS	3	Capacitor	15-34	909745	PCS	4	Seal ring
14	909710	PCS	3	Air filter	15-35	909746	PCS	2	Pipe
15	909711	PCS	3	Pump	15-36	909747	PCS	1	Wire clip
15-1	909712	PCS	2	Fan cover	16	909748	PCS	6	Cylinder head cover
15-2	909713	PCS	2	Screw	17	909749	PCS	31	Screw
15-3	909714	PCS	1	Fan(L)	18	909750	PCS	3	Elbow
15-4	909715	PCS	2	Crankshaft	19	909751	PCS	3	Exhaust pipe
15-5	909716	PCS	4	Screw	20	909752	PCS	12	Bolt
15-6	909717	PCS	2	Bearing(6006)	21	909753	PCS	12	Nut
15-7	909718	PCS	2	Connecting rod	22	909754	PCS	3	Magnetic valve
15-8	909719	PCS	2	Piston Ring	23	909755	PCS	3	Check valve
15-9	909720	PCS	2	Connecting rod cover	24	909756	PCS	1	Wire
15-10	909721	PCS	2	Cylinder	25	909757	PCS	1	Regulator with water trap
15-11	909722	PCS	2	Screw	26	909758	PCS	2	Quick couple
15-12	909723	PCS	4	Nut	27	909759	PCS	1	Twin Connector
15-13	909724	PCS	1	Crankcase (L)	28	909760	PCS	1	Safety valve
15-14	909725	PCS	2	Seal ring	29	909761	PCS	1	Pressure switch
15-15	909726	PCS	2	Screw	30	909762	PCS	1	Pressure gauge(φ40)
15-16	909727	PCS	2	Clip	31	909763	PCS	1	Pressure gauge(φ50)
15-17	909728	PCS	2	Valve(I)	32	909764	PCS	1	Power cable
15-18	909729	PCS	2	Valve Plate	33	909765	PCS	1	Drain valve
15-19	909730	PCS	2	Valve(O)	34	909766	PCS	2	Screw
15-20	909731	PCS	2	Position location pin	35	909767	PCS	1	Wire
15-21	909732	PCS	2	Screw	36	909768	PCS	1	Wire

SSC100PRO

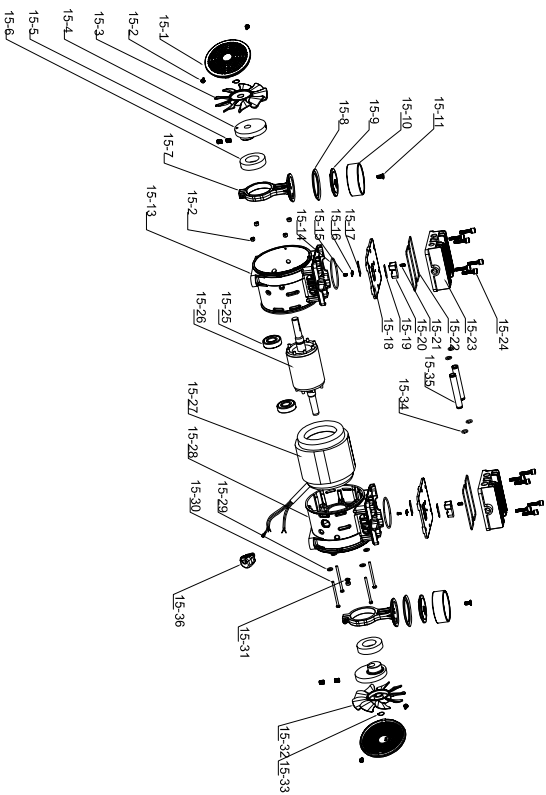
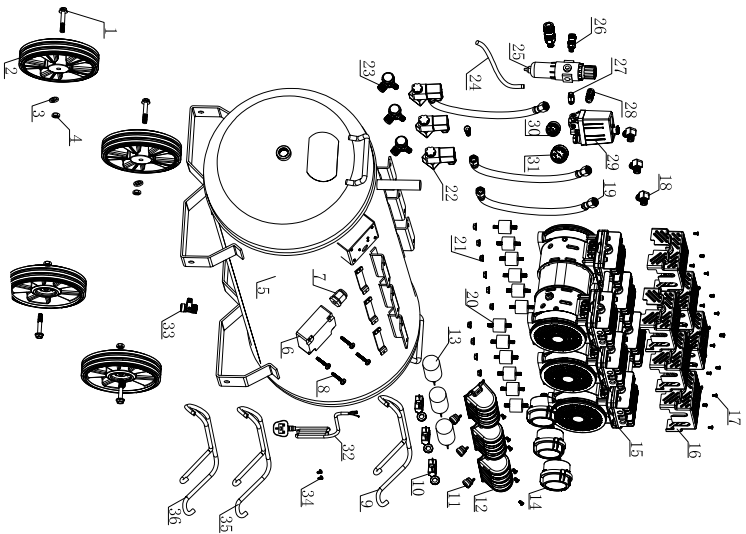

1. FOREWORD

1.1 IMPORTANT INFORMATION

Read carefully all the operating instructions, safety precautions and warnings in the Instruction Manual. Most accidents that occur when using the compressor are caused by failure to observe basic safety rules. Accidents can be avoided by recognising a potentially hazardous situation in time and by observing appropriate safety procedures. Basic safety precautions are outlined in the "SAFETY" section of this manual.

The hazardous situations that must be avoided to prevent risks of serious injuries or damage to the machine are indicated in the "WARNINGS" section. Never use the compressor inappropriately. Only use it as recommended by the manufacturer.

Key:

WARNING: indicates a potentially hazardous situation which, if ignored, could result in serious damage or injury.

CAUTION: indicates a hazardous situation which, if ignored, could result in moderate personal injury or machine damage.

NOTE: emphasizes essential information.

1.2 SAFETY RULES

IMPROPER USE AND POOR MAINTENANCE OF THIS COMPRESSOR MAY RESULT IN BODILY INJURY. TO AVOID THESE RISKS, PLEASE ADHERE STRICTLY TO THE FOLLOWING INSTRUCTIONS.

1. NEVER TOUCH MOVING PARTS

Never place your hands, fingers or other body parts near the compressor's moving parts.

2. NEVER OPERATE WITHOUT ALL GUARDS IN PLACE

Never operate this compressor without all the guards and safety features (e.g. fairings, belt guard, safety valve) perfectly fitted and in place. If maintenance or servicing requires the removal of these guards, make sure they are fitted properly in their original position before using the compressor again.

3. ALWAYS WEAR EYE PROTECTION

Always wear safety goggles or equivalent eye protection. Never aim compressed air at any part of your body or at others.

4. PROTECT YOURSELF AGAINST ELECTRIC SHOCK

Prevent accidental body contact with metal parts of the compressor such as pipes, the tank or grounded metal parts. Never operate the compressor in damp or wet locations.

5. DISCONNECT THE COMPRESSOR

Always disconnect the compressor from the power source and fully remove the compressed air from the air tank before servicing, inspecting, maintaining, cleaning, replacing or checking any parts.

6. UNINTENTIONAL START-UPS

Do not transport the compressor while it is connected to its power

source or when the air tank is pressurised. Make sure the knob of the pressure switch is in the OFF position before connecting the compressor to the power source.

7. STORE THE COMPRESSOR PROPERLY

When the compressor is not in use, it must be kept in a dry room protected against the weather. Keep out of reach of children.

8. WORK AREA

Keep the work area clean, if necessary clearing the area of any unnecessary tools. Keep the work area well ventilated. Do not use the compressor in the presence of flammable liquids or gases. The compressor can produce sparks during operation. Never use the compressor in situations where there could be paint, benzene, chemicals, adhesives or any other combustible or explosive materials.

9. KEEP CHILDREN AWAY

Prevent children or any other person from coming into contact with the compressor power cord. All visitors must be kept at a safe distance from the work area.

10. WORKING CLOTHES

Do not wear bulky clothes or jewellery, which could get caught by moving parts. Wear protective hair covering to contain long hair.

11. DO NOT ABUSE THE POWER CORD

Do not stretch the power cord when connecting the plug. Keep cable away from heat, oil, and sharp surfaces. Do not step on the power cord or crush it with heavy weights.

12. MAINTAIN THE COMPRESSOR CAREFULLY

Follow instructions for lubrication (not valid for oil-less). Inspect the power cord periodically and if it is damaged, have it repaired or replaced by an authorized service centre. Check the external appearance of the compressor for visible abnormalities. Please contact your nearest service centre if necessary.

13. ELECTRIC EXTENSION CORDS FOR OUTDOOR USE

When the compressor is used outdoors, only ever use extension cords designed and marked for outdoor use.

14. STAY ALERT

Pay attention to what you are doing. Use common sense. Do not use the compressor when you are tired. Never use the compressor if you are under the influence of alcohol, drugs or medicines that may cause drowsiness.

15. CHECK FOR FAULTY PARTS OR AIR LEAKS

Before using the compressor again, if a guard or any other parts are damaged, they must be carefully checked to determine whether they can operate safely as intended. Check alignment of moving parts, pipes, pressure gauges, pressure regulators, pneumatic connections and any other parts that may affect normal operation. Any

damaged parts must be properly repaired or replaced by an authorised service facility or replaced as indicated in this instruction manual. **DO NOT USE THE COMPRESSOR IF THE PRESSURE SWITCH IS DEFECTIVE.**

16. ONLY USE THE COMPRESSOR FOR THE SPECIFIED APPLICATIONS

The compressor is a machine that produces compressed air. Never use the compressor for any use other than those specified in the instruction manual.

17. USE THE COMPRESSOR CORRECTLY

Operate the compressor according to the instructions in this manual. Do not let children or anyone not familiar with its operation use the compressor.

18. CHECK THAT ALL SCREWS, BOLTS AND COVERS ARE SECURELY FASTENED.

Make sure that all screws, bolts and plates are securely fastened. Check periodically that they are tight.

19. KEEP THE AIR VENT CLEAN

Keep the motor ventilation grille clean. Clean this grid periodically if the working environment is very dirty.

20. OPERATE THE COMPRESSOR AT THE RATED VOLTAGE

Operate the compressor at the voltage specified on the electrical data plate. If using the compressor at a higher voltage than the rated voltage, it will result in abnormally fast motor revolution and may damage the unit and burn out the motor.

21. NEVER USE THE COMPRESSOR IF IT IS DEFECTIVE

If the compressor makes strange noises or excessive vibrations while it is running, or otherwise appears defective, stop using it immediately and check its functionality or contact the nearest authorised service centre.

22. DO NOT CLEAN PLASTIC PARTS WITH SOLVENTS

Solvents such as benzene, thinner, diesel fuel or other substances that contain alcohol can damage plastic parts. Do not wipe plastic parts with solvents. If necessary, clean these parts with a soft cloth and soapy water or appropriate liquids.

23. USE ONLY GENUINE REPLACEMENT PARTS

The use of non-original spare parts will void the warranty and cause the compressor to malfunction. Genuine spare parts are available from authorised distributors.

24. DO NOT MODIFY THE COMPRESSOR

Do not modify the compressor. Consult an authorized service centre for all repairs. Unauthorised modification may not only impair compressor performance but may also result in accident or injury to repair personnel who do not have the required knowledge and technical expertise to perform the repair operations correctly.

25. SWITCH OFF WHEN NOT IN USE

When the compressor is not in use, turn the knob of the pressure switch to the "0" (OFF) position, disconnect it from the power source and open the drain cock to discharge the compressed air from the air tank.

26. DO NOT TOUCH HOT PARTS OF THE COMPRESSOR

Do not touch the pipes, motor or any other hot parts.

27. DO NOT DIRECT THE AIR STREAM AT THE BODY

Never direct the air stream at people or animals.

28. DRAIN CONDENSATE FROM THE TANK

Drain the tank daily or every 4 hours of service. Open the drain fitting and tilt the compressor if necessary to remove accumulated water.

29. DO NOT STOP BY PULLING ON THE POWER CORD

Use the "0/I" (ON/OFF) switch of the pressure switch to stop the compressor.

30. PNEUMATIC CIRCUIT

Use recommended tubes and pneumatic tools that can withstand a pressure greater than or equal to the maximum operating pressure of the compressor.

1.3 INTENDED USE

The models described in this manual are designed and manufactured for intermittent use with a maximum service factor of 30% (e.g. 3 minutes of work and 7 minutes of rest), under optimal environmental conditions (max. temp 25°C). Respecting these guidelines and the prescribed maintenance intervals will allow the product to work properly over time.



1.4 GROUND CONNECTION

The single-phase compressor is equipped with an electrical cable and a two-pole + earth plug. It is recommended not to make any other connections on the pressure switch. Repairs must always be carried out by a qualified technician.

1.5 USE OF AN EXTENSION CABLE

Only use extension cables with plug and ground connection. Do not use damaged or crushed extension cords. An extension cable that is too thin can cause voltage drops, loss of power and overheating of the unit. The extension cable must have a cross-section proportionate to its length.

Check table A in order to choose the correct cable size

Tab. A		
Volt	220-240	110-120
		
kW / HP	mm ² (*)	mm ² (*)
0,75 / 11	,5	2,5
(*) Cable cross-section for maximum length 20 m		

WARNINGS

Avoid all risks of electric shock. Never use the compressor with a damaged electrical cable or extension cord. Check all electrical cables on a regular basis. Never use the compressor in or near water or near a hazardous environment where electric shocks are possible.

2. INSTALLATION AND USE

Note: The information in this manual is provided to assist the operator in operating and maintaining the compressor. Some illustrations may show details different from those of your compressor.

WE RESERVE THE RIGHT TO MAKE ANY CHANGES WITHOUT PRIOR NOTICE WHERE NECESSARY

2.1 INSTALLATION

Remove the compressor from its packing, make sure it is in perfect condition and that it was not damaged during transport, and **carry out the following operations:**

- Fit the wheels and/or the rubber tab.
- Place the compressor on a flat surface, or with a slope of no more than 10°, in a well-ventilated place, protected against atmospheric agents and in a non-explosive environment.
- **MAKE SURE THAT THE COMPRESSOR IS TRANSPORTED PROPERLY, DO NOT OVERTURN IT OR LIFT IT WITH HOOKS OR ROPES.**
- If positioned on an inclined plane, make sure that the compressor does not move and, if necessary, block the wheels with appropriate means. If placed on a bracket or shelf top, make sure that the support can bear the weight and secure it properly so that it cannot fall.
- To ensure proper ventilation and effective cooling, the compressor must be at least 50 cm away from any wall or obstacle.

2.2 ELECTRICAL CONNECTION

The compressors are supplied with an electrical cable and a two-pole + earth plug. The compressor must be connected to grounded power socket protected by a suitable differential switch (magneto-thermal).

2.3 START-UP

Check that the mains power matches the power indicated on the electrical data-plate. The permissible tolerance range is +/-5%.

- Insert the plug into the power outlet and start the compressor by turning the pressure switch knob to the "1 / ON" position.
- The compressor is fully automatic, and is controlled by the pressure switch which stops it when tank pressure reaches the maximum value and restarts it when it falls to the minimum value. The pressure difference between maximum and minimum values is usually about 2 bar (29 psi).

E.g. the compressor stops when it reaches 8 bar (116 psi – maximum operating pressure) and restarts automatically when the pressure in the tank drops to 6 bar (87 psi).

After connecting the compressor to the power line, load it to maximum pressure and check that the machine works properly. Some models are equipped with a head discharge valve, which facilitates the subsequent start-up. In this case, a puff of air is normal when the motor stops.

2.4 MOTOR PROTECTION DEVICES

The compressors are equipped with an amperometric thermal breaker with manual reset, located outside the terminal board cover. When a thermal trip occurs, wait a few minutes and then reset the RESET switch manually.

If the protection device trips again at the subsequent restart, it is highly recommended stop the compressor, disconnect the power supply and contact an authorised service centre.

2.5 ADJUSTING THE OPERATING PRESSURE

It is not always necessary to use the maximum pressure. Most of the time pneumatic tools work at a lower pressure. Always check the correct operating pressure of the tool you intend to use.

In compressors supplied with a pressure regulator, operating pressure must be correctly adjusted. Adjust the pressure to the desired value by turning the knob clockwise to increase it and anti-clockwise to decrease it. When the desired pressure is reached (which you can check on the pressure gauge), lock the knob by pressing it downwards. If there is no pressure regulator on the machine, the user must fit suitable means for intercepting and reducing the pressure on the distribution line.

2.6 CAUTIONS WHILE USING

- Do not unscrew any connection while the tank is pressurised. Always make sure the tank is pressure free.
- Do not drill holes, weld or purposely deform the compressed air tank.
- Do not carry out any work on the compressor without first unplugging it from the wall outlet.
- Recommended ambient operating temperature 0°C +35°C
- Do not direct jets of water or flammable liquids onto the compressor.
- Do not place flammable objects near the compressor.
- During downtimes, turn the pressure switch to position "0" (OFF)
- Never direct the air jet towards people or animals.
- Do not transport the compressor with the tank under pressure.
- Please note that some parts of the compressor such as the compressor head and delivery pipes can reach high temperatures. Do not touch these components to avoid burns.
- Transport the compressor, lifting or pulling it with the appropriate grips or handles.
- Keep children and animals well away from the machine operating area.
- If using the compressor for painting:
 - a) Do not work in closed environments or near to naked flames
 - b) Make sure there is adequate air exchange in the environment where you are operating
 - c) Protect the nose and mouth with a mask.
- If the power cord or plug is damaged, do not use the compressor.

Please contact your authorised service centre to replace it with an original part.

- Do not insert objects and/or hands inside the protection grilles.
- Always unplug the plug from the wall outlet after use.

3. MAINTENANCE

BEFORE CARRYING OUT ANY WORK ON THE COMPRESSOR, MAKE SURE OF THE FOLLOWING:

- The master power switch is in position "0".
- The pressure switch and/or switches on the control unit are switched off (position "0/Off").
- The air tank is NOT under pressure.
- On models where the fairing has to be removed in order to access the internal parts, make sure you do not pull cables or connections.

3.1 CLEANING/REPLACING THE AIR FILTER

Every 50 hours of duty: dismantle the air filter and clean the filtering element by blowing with compressed air.

Replace the filter element at least once a year if the compressor operates in a clean environment, but more frequently if in a dusty environment.

Before restarting the compressor, reassemble all parts correctly.

3.2 DRAINING CONDENSATE

The compressor generates condensate water which accumulates in the tank. The condensate in the tank must be drained at least once a week by opening the condensate drain under the tank. Make sure the tank is not under pressure.

CONDENSATE MUST NOT BE DRAINED INTO THE SEWER OR DISPERSED IN THE ENVIRONMENT.

4. TROUBLESHOOTING

Air leakage from the valve under the pressure switch:

This could be caused by imperfect tightness of the check valve.

Discharge all pressure from the tank.

Unscrew the hexagonal head of the valve and thoroughly clean both the element and its seat. Reassemble the valve.

Air leaks:

These can be caused by poor tightness of a union.

Check all the unions, wetting them with soapy water.

The compressor runs but does not load:

This may be due to failure of the valves or a seal. Contact a service centre.

If the compressor has difficulty starting up, check the following:

Does the mains power match the power on the data plate. Are power cable extensions of adequate diameter or length?

Is the work environment too cold? (under 0°C)

Has the motor protection tripped? (see 2.4).

Is the electrical line powered and is the system is correctly dimensioned?

If the compressor does not stop when maximum pressure is reached, the tank safety valve will enter into operation. In this case, you must contact your nearest authorised service centre to arrange a check.

5. NOTES

5.1 TECHNICAL DATA

- Refer to the label on the compressor.
- For the European market, the compressor tanks are manufactured to meet Directives CE 2006/42 e CE 2009/105 (tank).
- The sound pressure level measured in a free range at a distance of 1 m \pm 3dB(A) at the maximum operating pressure.
- The sound level value can increase from 1 to 10 dB(A) depending on the environment in which the compressor is installed.

5.2 STORING THE PACKED AND UNPACKED COMPRESSOR

For as long as the compressor remains idle before unpacking, store it in a dry place with a temperature between + 5°C and + 45°C and sheltered against the weather.

For as long as the compressor remains idle after unpacking, waiting for commissioning or due to production stoppages, protect it with tarpaulins to prevent dust from settling on the mechanisms.

If the compressor is idle for long periods of time, the oil must be replaced and the operational efficiency of the compressor needs to be checked.

5.3 PNEUMATIC CONNECTIONS

Make sure to always use pneumatic tubes for compressed air with maximum pressure characteristics that are adequate for the compressor.

Never attempt to repair faulty tubes.

5. DISPOSAL

The appliance may not be disposed of with household rubbish.

This appliance is labelled in accordance with European Directive 2012/19/EU concerning used electrical and electronic appliances (waste electrical and electronic equipment - WEEE).

This directive defines the standards for the collection and recycling of used appliances valid throughout the European Union. To return a used device, please use the return and collection systems available in the individual countries of use.

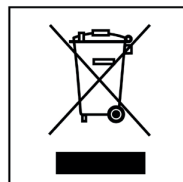

SGS-ENGINEERING.COM



SGS Engineering (UK) Ltd
Unit 1 West Side Park
Raynesway
Derby, DE21 7AZ

EC Declaration of Conformity

This is an important document and should be retained

MANUFACTURER'S NAME: SGS Engineering (UK) Ltd
TYPE OF EQUIPMENT: Air Compressor
PART NUMBER: SSC100PRO

APPLICATION OF EC COUNCIL DIRECTIVES / STANDARD:

EN 1012-1: 2010
EN 60204-1: 2018
the Machinery Directive 2006/42/EC
EN IEC 55014-1:2021
EN IEC 55014-2:2021
EN IEC 61000-3-2:2019+A1:2021
EN 61000-3-3:2013+A1:2019+A2:2021
The EMC directive 2014/30/EU
9 Anhang I 2000/14/EG (Annex I of 2000/14/EC)
(RoHS Directive
2011/65/EU and (EU) 2015/863)

I, the undersigned, hereby declare that the equipment specified above conforms to the above European Communities Directive(s) and Standard(s).

PLACE: Derby, UK

DATE: 07 OCTOBER 2024

(Signature)

Neil Sansom
CEO

